



Township of Lakewood

DEPARTMENT OF INSPECTIONS

212 FOURTH STREET
LAKEWOOD, NEW JERSEY 08701
732-364-3760
FAX: 732-905-8112

JEREMY KUIPERS
Construction Official

Name: _____

Date: _____

Address: _____

Block: _____ Lot: _____

This is to assist you in determining how to comply with the I.R.C. Code Requirements and to expedite your pool permit. This does not interpret or take place of the actual wording of the code or everything that the code may allow. See attached I.R.C. section AG on page 3 of this packet for further details.

Note: ALL Barriers must be owned by the permit applicant. UNDER NO circumstances are you to use a neighbor's fence as a barrier.

Part 1: Barrier Method. (Please check off proposed method).	
1. Minimum 4-foot-high barrier around pool. See page 3, example 1.	
2. Minimum 4-foot-high barrier around pool connecting the house. See page 3, example 2.	
3. Minimum 4-foot-high barrier around the ladder or an above ground pool or a pre-constructed ladder enclosure complying with code where the pool wall is a minimum of 4-ft above the ground. See page 3, example 3.	
4. If you are using a deck as part of your barrier certain requirements may apply. Please draw your deck & method in the blank space provided on Page 3.	

Part 2: Type of Barrier (Please check off proposed method).	
1. Stockade fence. Minimum 4-foot-high with maximum spaces of vertical members at 1 3/4".	
2. Board of board fence. Minimum 4-ft-high with maximum spaces of vertical members at 1 3/4".	
3. Picket fence. Minimum 4-ft-high. Spacing can be 4" if horizontal members are more than 45" apart. If members are less than 45" apart spacing must be 1 3/4".	
4. Chain Link Fence. Minimum 4-ft-high with maximum mesh size openings of 1 3/4" (Mini Chain Link).	
5. If larger Chain Link Fence is used slats may be installed to reduce the openings to not more than 1 3/4"	
6. Lattice fence. Minimum of 4-ft-high with diagonal members forming openings of not more than 1 3/4".	
7. If other, please write & draw in the space provided on page 3 with as much detail as possible of your proposed type of barrier.	

If you are using your existing fence as your required barrier, it must meet the requirements of the International Residential Code 2021.

I have read and understand the 2021 I.R.C. building regulations on page 3 & can attest that the existing barrier or new barrier will comply with the 2021 I.R.C. building code.

Signature: _____

Date: _____

***Omission of any information will only delay the plan review process.**



Township of Lakewood

DEPARTMENT OF INSPECTIONS

212 FOURTH STREET
LAKEWOOD, NEW JERSEY 08701
732-364-3760
FAX: 732-905-8112

JEREMY KUIPERS
Construction Official

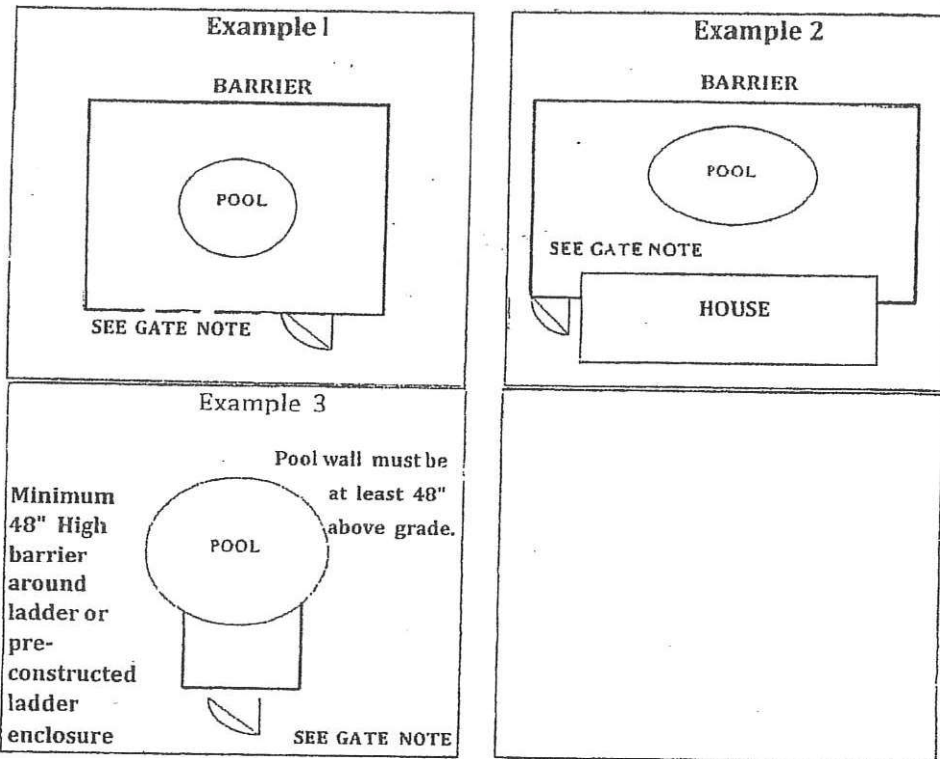

Note: All barriers must be owned by the permit applicant. UNDER NO circumstances are you to use any neighbor's fence as a barrier.

Access Gate

Pedestrian access gates shall open away from the pool and shall be self-closing with self-latching devices. Devices are to be 54" above grade or 3" below the top of the barrier where the device is on the pool side of the gate and there are no openings greater than 1/2" within 18' of the device.

I have read and understood the 2021 I.R.C. building regulations on page 3 & can attest that the existing barrier or new barrier will comply with the 2021 I.R.C. building code.

Signature: _____

Date: _____

CHAPTER 7

ONGROUND STORABLE RESIDENTIAL SWIMMING POOLS

User note:

About this chapter: Chapter 7 concerns residential portable pools also known as onground storable residential swimming pools. These pools are manufactured for assembly on the site. The chapter's regulations include those for floor slopes, entry barrier methods, decks, stairs, safety signage and circulation systems.

SECTION 701 GENERAL

701.1 Scope. This chapter describes certain criteria for the design, manufacturing, and testing of *onground storable pools* intended for *residential* use. This includes portable pools with flexible or nonrigid side walls that achieve their structural integrity by means of uniform shape, support frame or a combination thereof, and that can be disassembled for storage or relocation. This chapter includes what has been commonly referred to in past standards or codes as onground or above-ground pools.

701.1.1 Permanent inground residential swimming pool. This chapter does not apply to permanent inground *residential* pools, as defined in Chapter 8.

701.2 General. In addition to the requirements of this chapter, onground storable *residential* swimming pools shall comply with the requirements of Chapter 3.

701.3 Floor slopes. Floor slopes shall be uniform and in accordance with Sections 701.3.1 through 701.3.4.

701.3.1 Shallow end. The slope of the floor from the shallow end wall towards the deep area shall not exceed 1 unit vertical in 7 units horizontal (14-percent slope) to the point of the first slope change.

701.3.2 Transition. The slope of the floor from the point of the first slope change towards the deepest point shall not exceed 1 unit vertical in 3 units horizontal (33-percent slope).

701.3.3 Adjacent. The slope adjacent to the shallow area shall not exceed 1 unit vertical in 3 units horizontal (33-percent slope) and the slope adjacent to the side walls shall not exceed 1 unit vertical in 1 unit horizontal (100-percent slope).

701.3.4 Change point. The point of the first slope change shall be defined as the point at which the shallow area slope exceeds 1 unit vertical in 7 units horizontal (14-percent slope) and is not less than 6 feet (1889 mm) from the shallow end wall of the pool.

701.4 Identification. For onground storable *residential* pools with a vinyl liner, the manufacturer's name and the liner identification number shall be affixed to the liner. For onground storable *residential* pools without a liner, the manufacturer's name and identification number shall be affixed to the exterior of the pool structure.

701.5 Installation. *Onground storable pools* shall be installed in accordance with the manufacturer's instructions.

SECTION 702 LADDERS AND STAIRS

702.1 Ladders and stairs. Pools shall have a means of entry and exit consisting of not less than one ladder or a ladder and staircase combination.

702.2 Type A and Type B ladders. Type A, double access, and Type B, limited access, A-frame ladders shall comply with Sections 702.2.1 through 702.2.7. See Figure 702.2.

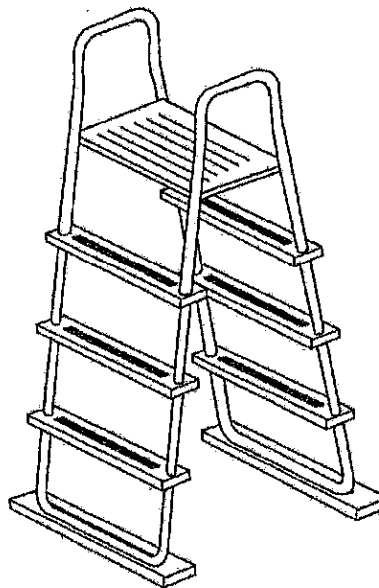

FIGURE 702.2
TYPICAL A-FRAME LADDER, TYPES A AND B

702.2.1 Barrier required. Ladders in the pool shall have a physical barrier to prevent children from swimming through the riser openings or behind the ladder.

Exception: Barriers for ladders shall not be required where the ladder manufacturer provides a certification statement that the ladder complies with the ladder entrapment test requirements of APSP 4.

702.2.2 Platform. Where an A-frame ladder has a platform between the handrails, the platform shall have a width of not less than 12 inches (305 mm) and a length of not less than 12 inches (305 mm). The platform shall be at or above the highest ladder tread. The walking surface of the platform shall be slip resistant.

702.2.3 Handrails or handholds. A-frame ladders shall have two handrails or handholds that serve all treads. The height of the handrails and handholds shall be not less than 20 inches (508 mm) above the platform or uppermost tread, whichever is higher.

702.2.4 Diameter. The outside diameter of handrails and handholds shall be not less than 1 inch (25 mm) and not greater than 1.9 inches (48 mm).

702.2.5 Clear distance. The clear distance between ladder handrails shall be not less than a space of 12 inches (305 mm).

702.2.6 Treads. Ladder treads shall have a horizontal uniform depth of not less than 2 inches (51 mm).

702.2.7 Riser height. Risers, other than the bottom riser, shall be of uniform height that is not less than 7 inches (178 mm) and not greater than 12 inches (305 mm). The bottom riser height shall be not less than 7 inches (178 mm) and not greater than 12 inches (305 mm). The vertical distance from the platform or top of the pool structure to the uppermost tread shall be the same as the uniform riser heights.

702.3 Type C staircase ladders (ground to deck). Type C staircase ladders shall comply with Sections 702.3.1 through 702.3.6. See Figure 702.3.

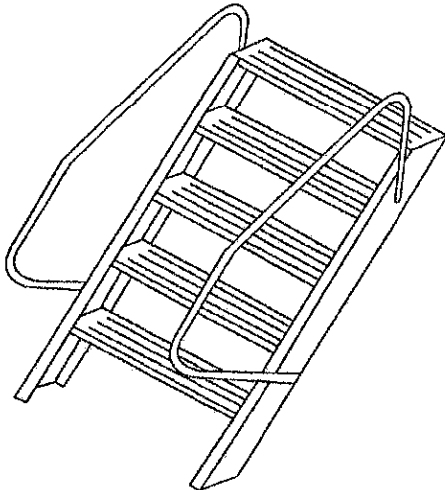

FIGURE 702.3
TYPICAL STAIRCASE LADDER, TYPE C

702.3.1 Handrails or handholds. Staircase ladders shall have not less than two handrails or handholds that serve all treads. The height of the handrails and handholds shall be not less than 20 inches (508 mm) above the platform or uppermost tread, whichever is higher.

702.3.2 Diameter. The outside diameter of handrails and handholds shall be not less than 1 inch (25 mm) and not greater than 1.9 inches (48 mm).

702.3.3 Treads. Ladder treads shall have a horizontal uniform depth of not less than 4 inches (102 mm).

702.3.4 Riser height. Risers, other than the bottom riser, shall be of uniform height that is not less than 7 inches (178 mm) and not greater than 12 inches (305 mm). The bottom riser height shall be not less than 7 inches (178 mm) and not greater than 12 inches (305 mm). The vertical distance from the platform or top of the pool structure to the uppermost tread shall be the same as the uniform riser heights.

702.3.5 Top step. The top step of a staircase ladder shall be flush with the deck or 7 inches (178 mm) to 12 inches (305 mm) below the deck level.

702.3.6 Width. Steps shall have a minimum unobstructed width of 19 inches (483 mm) between the side rails.

702.4 Type D in-pool ladders. Type D in-pool ladders shall be in accordance with Sections 702.4.1 through 702.4.7. See Figure 702.4.

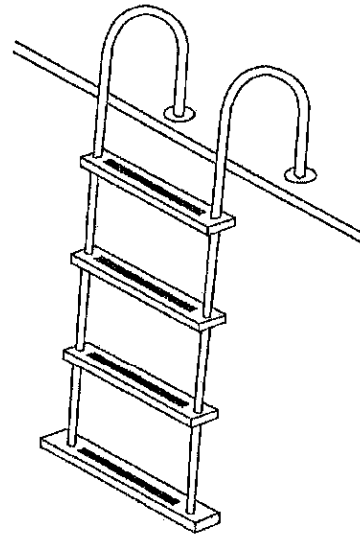

FIGURE 702.4
TYPICAL IN-POOL LADDER, TYPE D

702.4.1 Clearance. There shall be a clearance of not less than 3 inches (76 mm) and not greater than 6 inches (152 mm) between the pool wall and the ladder.

702.4.2 Handrails or handholds. Ladders shall be equipped with two handrails or handholds that extend above the platform or deck not less than 20 inches (508 mm).

702.4.3 Clear distance. The clear distance between ladder handrails shall be not less than 12 inches (305 mm).

702.4.4 Diameter. The outside diameter of handrails and handholds shall be not less than 1 inch (25 mm) and not greater than 1.9 inches (48 mm).

702.4.5 Riser height. Risers, other than the bottom riser, shall be of uniform height that is not less than 7 inches (178 mm) and not greater than 12 inches (305 mm). The bottom riser height shall be not less than 7 inches (178 mm) and not greater than 12 inches (305 mm).

702.4.6 Top tread. The vertical distance from the pool coping, deck, or step surface to the uppermost tread shall be not less than 7 inches (178 mm) and not greater than 12 inches (305 mm) and uniform with other riser heights.

702.4.7 Tread depth. Ladder treads shall have a horizontal uniform depth of not less than 2 inches (51 mm).

702.5 Type E protruding in-pool stairs. Type E protruding in-pool stairs shall be in accordance with Sections 702.5.1 through 702.5.7. See Figure 702.5.

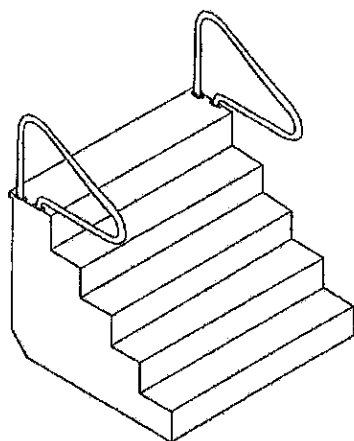

FIGURE 702.5
TYPICAL IN-POOL STAIRCASE, TYPES E AND F

702.5.1 Barrier required. In-pool stairs shall have a physical barrier to prevent children from swimming through the riser openings or behind the in-pool stairs.

702.5.2 Handrails or handholds. In-pool stairs shall be equipped with not less than one handrail or handhold that serves all treads with a height of not less than 20 inches (508 mm) above the platform or uppermost tread, whichever is higher.

702.5.3 Removable handrails. Where handrails are removable, they shall be installed such that they cannot be removed without the use of tools.

702.5.4 Leading edge distance. The leading edge of handrails shall be 18 inches (457 mm) \pm 3 inches (\pm 76 mm), horizontally from the vertical plane of the bottom riser.

702.5.5 Diameter. The outside diameter of handrails and handholds shall be not less than 1 inch (25 mm) and not greater than 1.9 inches (48 mm).

702.5.6 Tread width and depth. Treads shall have an unobstructed horizontal depth of not less than 10 inches (254 mm) and an unobstructed surface area of not less than 240 square inches (0.15 m²).

702.5.7 Uniform riser height. Risers, other than the bottom riser, shall be of uniform height that is not less than 7 inches (178 mm) and not greater than 12 inches (305 mm). The bottom riser height shall be not less than 7 inches (178 mm) and not greater than 12 inches (305 mm). The vertical distance from the pool coping, deck or step surface to the uppermost tread of the stairs shall be the same as the uniform riser heights.

702.6 Type F recessed in-pool stairs. Type F recessed in-pool stairs shall be in accordance with Sections 702.6.1 through 702.6.7. See Figure 702.5.

702.6.1 Barrier required. In-pool stairs shall have a physical barrier to prevent children from swimming through the riser openings or behind the in-pool stairs.

702.6.2 Handrails or handholds. In-pool stairs shall be equipped with not less than one handrail or handhold that serves all treads with a height of not less than 20 inches (508 mm) above the platform or uppermost tread, whichever is higher.

702.6.3 Removable handrails. Where handrails are removable, they shall be installed such that they cannot be removed without the use of tools.

702.6.4 Leading edge distance. The leading edge of handrails shall be 18 inches (457 mm) \pm 3 inches (\pm 76 mm), horizontally from the vertical plane of the bottom riser.

702.6.5 Diameter. The outside diameter of handrails and handholds shall be not less than 1 inch (25 mm) and not greater than 1.9 inches (48 mm).

702.6.6 Tread width and depth. Treads shall have an unobstructed horizontal depth of not less than 10 inches (254 mm) at all points and an unobstructed surface area of not less than 240 square inches (0.15 m²).

702.6.7 Uniform riser height. Risers, other than the bottom riser, shall be of uniform height that is not less than 7 inches (178 mm) and not greater than 12 inches (305 mm). The bottom riser height shall be not less than 7 inches (178 mm) and not greater than 12 inches (305 mm). The vertical distance from the pool coping, deck or step surface to the uppermost tread of the stairs shall be the same as the uniform riser heights.

SECTION 703 DECKS

703.1 General. Decks provided by the pool manufacturer shall be installed in accordance with the manufacturer's instructions. Decks fabricated on-site shall be in accordance with the *International Residential Code*.

703.2 Cantilevered. The top surface of a cantilevered deck shall be not greater than 1 inch (25 mm) higher than the top of the pool wall. See Figure 703.4. The top surface of a noncan-

**SECTION 305
BARRIER REQUIREMENTS**

305.1 General. The provisions of this section shall apply to the design of barriers for restricting entry into areas having pools and spas. Where spas or hot tubs are equipped with a lockable safety cover complying with ASTM F1346 and swimming pools are equipped with a powered safety cover that complies with ASTM F1346, the areas where those spas, hot tubs or pools are located shall not be required to comply with Sections 305.2 through 305.7.

305.2 Outdoor swimming pools and spas. Outdoor pools and spas and indoor swimming pools shall be surrounded by a barrier that complies with Sections 305.2.1 through 305.7.

305.2.1 Barrier height and clearances. Barrier heights and clearances shall be in accordance with all of the following:

1. The top of the barrier shall be not less than 48 inches (1219 mm) above grade where measured on the side of the barrier that faces away from the pool or spa. Such height shall exist around the entire perimeter of the barrier and for a distance of 3 feet (914 mm) measured horizontally from the outside of the required barrier.
2. The vertical clearance between grade and the bottom of the barrier shall not exceed 2 inches (51 mm) for grade surfaces that are not solid, such as grass or gravel, where measured on the side of the barrier that faces away from the pool or spa.
3. The vertical clearance between a surface below the barrier to a solid surface, such as concrete, and the bottom of the required barrier shall not exceed 4 inches (102 mm) where measured on the side of the required barrier that faces away from the pool or spa.
4. Where the top of the pool or spa structure is above grade, the barrier shall be installed on grade or shall be mounted on top of the pool or spa structure. Where the barrier is mounted on the top of the pool or spa, the vertical clearance between the top of the pool or spa and the bottom of the barrier shall not exceed 4 inches (102 mm).

305.2.2 Openings. Openings in the barrier shall not allow passage of a 4-inch-diameter (102 mm) sphere.

305.2.3 Solid barrier surfaces. Solid barriers that do not have openings shall not contain indentations or protrusions that form handholds and footholds, except for normal construction tolerances and tooled masonry joints.

305.2.4 Mesh fence as a barrier. Mesh fences, other than chain link fences in accordance with Section 305.2.7, shall be installed in accordance with the manufacturer's instructions and shall comply with the following:

1. The bottom of the mesh fence shall be not more than 1 inch (25 mm) above the deck or installed surface or grade.
2. The maximum vertical clearance from the bottom of the mesh fence and the solid surface shall not permit

the fence to be lifted more than 4 inches (102 mm) from grade or decking.

3. The fence shall be designed and constructed so that it does not allow passage of a 4-inch (102 mm) sphere under any mesh panel. The maximum vertical clearance from the bottom of the mesh fence and the solid surface shall be not greater than 4 inches (102 mm) from grade or decking.
4. An attachment device shall attach each barrier section at a height not lower than 45 inches (1143 mm) above grade. Common attachment devices include, but are not limited to, devices that provide the security equal to or greater than that of a hook-and-eye-type latch incorporating a spring-actuated retaining lever such as a safety gate hook.
5. Where a hinged gate is used with a mesh fence, the gate shall comply with Section 305.3.
6. Patio deck sleeves such as vertical post receptacles that are placed inside the patio surface shall be of a nonconductive material.
7. Mesh fences shall not be installed on top of onground *residential* pools.

305.2.5 Closely spaced horizontal members. Where the barrier is composed of horizontal and vertical members and the distance between the tops of the horizontal members is less than 45 inches (1143 mm), the horizontal members shall be located on the pool or spa side of the fence. Spacing between vertical members shall not exceed $1\frac{3}{4}$ inches (44 mm) in width. Where there are decorative cutouts within vertical members, spacing within the cutouts shall not exceed $1\frac{3}{4}$ inches (44 mm) in width.

305.2.6 Widely spaced horizontal members. Where the barrier is composed of horizontal and vertical members and the distance between the tops of the horizontal members is 45 inches (1143 mm) or more, spacing between vertical members shall not exceed 4 inches (102 mm). Where there are decorative cutouts within vertical members, the interior width of the cutouts shall not exceed $1\frac{1}{4}$ inches (44 mm).

305.2.7 Chain link dimensions. The maximum opening formed by a chain link fence shall be not more than $1\frac{3}{4}$ inches (44 mm). Where the fence is provided with slats fastened at the top and bottom that reduce the openings, such openings shall be not greater than $1\frac{1}{2}$ inches (44 mm).

305.2.8 Diagonal members. Where the barrier is composed of diagonal members, the maximum opening formed by the diagonal members shall be not greater than $1\frac{3}{4}$ inches (44 mm). The angle of diagonal members shall be not greater than 45 degrees (0.79 rad) from vertical.

305.2.9 Clear zone. There shall be a clear zone of not less than 36 inches (914 mm) between the exterior of the barrier and any permanent structures or equipment such as pump, filters and heaters that can be used to climb the barrier.

305.2.10 Poolside barrier setbacks. The pool or spa side of the required barrier shall be not less than 20 inches (508 mm) from the water's edge.

305.3 Gates. Access gates shall comply with the requirements of Sections 305.3.1 through 305.3.3 and shall be equipped to accommodate a locking device. Pedestrian access gates shall open outward away from the pool or spa, shall be self-closing and shall have a self-latching device.

305.3.1 Utility or service gates. Gates not intended for pedestrian use, such as utility or service gates, shall remain locked when not in use.

305.3.2 Double or multiple gates. Double gates or multiple gates shall have not fewer than one leaf secured in place and the adjacent leaf shall be secured with a self-latching device. The gate and barrier shall not have openings larger than $\frac{1}{2}$ inch (12.7 mm) within 18 inches (457 mm) of the latch release mechanism. The self-latching device shall comply with the requirements of Section 305.3.3.

305.3.3 Latches. Where the release mechanism of the self-latching device is located less than 54 inches (1372 mm) from grade, the release mechanism shall be located on the pool or spa side of the gate not less than 3 inches (76 mm) below the top of the gate, and the gate and barrier shall not have openings greater than $\frac{1}{2}$ inch (12.7 mm) within 18 inches (457 mm) of the release mechanism.

305.4 Structure wall as a barrier. Where a wall of a dwelling or structure serves as part of the barrier and where doors or windows provide direct access to the pool or spa through that wall, one of the following shall be required:

1. Operable windows having a sill height of less than 48 inches (1219 mm) above the indoor finished floor and doors shall have an alarm that produces an audible warning when the window, door or their screens are opened. The alarm shall be *listed* and *labeled* as a water hazard entrance alarm in accordance with UL 2017. In dwellings or structures not required to be Accessible units, Type A units or Type B units, the operable parts of the alarm deactivation switches shall be located 54 inches (1372 mm) or more above the finished floor. In dwellings or structures required to be Accessible units, Type A units or Type B units, the operable parts of the alarm deactivation switches shall be located not greater than 54 inches (1372 mm) and not less than 48 inches (1219 mm) above the finished floor.
2. A *safety cover* that is *listed* and *labeled* in accordance with ASTM F1346 is installed for the pools and spas.
3. An *approved* means of protection, such as self-closing doors with self-latching devices, is provided. Such means of protection shall provide a degree of protection that is not less than the protection afforded by Item 1 or 2.

305.5 Onground residential pool structure as a barrier. An onground *residential* pool wall structure or a barrier mounted on top of an onground *residential* pool wall structure shall serve as a barrier where all of the following conditions are present:

1. Where only the pool wall serves as the barrier, the bottom of the wall is on grade, the top of the wall is not less than 48 inches (1219 mm) above grade for the

entire perimeter of the pool, the wall complies with the requirements of Section 305.2 and the pool manufacturer allows the wall to serve as a barrier.

2. Where a barrier is mounted on top of the pool wall, the top of the barrier is not less than 48 inches (1219 mm) above grade for the entire perimeter of the pool, and the wall and the barrier on top of the wall comply with the requirements of Section 305.2.
3. Ladders or steps used as means of access to the pool are capable of being secured, locked or removed to prevent access except where the ladder or steps are surrounded by a barrier that meets the requirements of Section 305.
4. Openings created by the securing, locking or removal of ladders and steps do not allow the passage of a 4-inch (102 mm) diameter sphere.
5. Barriers that are mounted on top of onground residential pool walls are installed in accordance with the pool manufacturer's instructions.

305.6 Natural barriers. In the case where the pool or spa area abuts the edge of a lake or other natural body of water, public access is not permitted or allowed along the shoreline, and required barriers extend to and beyond the water's edge not less than 18 inches (457 mm), a barrier is not required between the natural body of water shoreline and the pool or spa.

305.7 Natural topography. Natural topography that prevents direct access to the pool or spa area shall include but not be limited to mountains and natural rock formations. A natural barrier approved by the governing body shall be acceptable provided that the degree of protection is not less than the protection afforded by the requirements or Sections 305.2 through 305.5.

**SECTION 306
DECKS**

306.1 General. The structural design and installation of decks around pools and spas shall be in accordance with the *International Residential Code* or the *International Building Code*, as applicable in accordance with Section 102.7 and this section.

306.2 Slip resistant. Decks, ramps, coping, and similar step surfaces shall be slip resistant and cleanable. Special features

in or on decks such as markers, brand insignias, and similar materials shall be slip resistant.

306.3 Step risers and treads. Step risers for decks of public pools and spas shall be uniform and have a height not less than 3 inches (95 mm) and not greater than 7 inches (191 mm). The tread distance from front to back shall be not less than 11 inches (279 mm). Step risers for decks of residential pools and spas shall be uniform and shall have a height not exceeding 7½ inches (191 mm). The tread distance from front to back shall be not less than 10 inches (254 mm).

306.4 Deck steps handrail required. Public pool and spa deck steps having three or more risers shall be provided with a handrail.

306.5 Slope. The minimum slope of decks shall be in accordance with Table 306.5 except where an alternative drainage method is provided that prevents the accumulation or pooling of water. The slope for decks, other than wood decks, shall be not greater than 1/2 inch per foot (13 mm per 24 mm) except for ramps. The slope for wood and wood/plastic composite decks shall be not greater than 1/4 inch per 1 foot (1 mm per 48 mm). Decks shall be sloped so that standing water will not be deeper than 1/8 inch (3.2 mm), 20 minutes after the cessation of the addition of water to the deck.

306.6 Gaps. Gaps shall be provided between deck boards in wood and wood/plastic composite decks. Gaps shall be consistent with approved engineering methods with respect to the type of wood used and shall not cause a tripping hazard.

306.6.1 Maximum gap. The open gap between pool decks and adjoining decks or walkways, including joint material, shall be not greater than 1/4 inch (19.1 mm). The difference in vertical elevation between the pool deck and the adjoining sidewalk shall be not greater than 1/4 inch (6.4 mm).

306.7 Concrete joints. Isolation joints that occur where the pool coping meets the concrete deck shall be water tight.

306.7.1 Joints at coping. Joints that occur where the pool coping meets the concrete deck shall be installed to protect the coping and its mortar bed from damage as a result of the anticipated movement of adjoining deck.

306.7.2 Crack control. Joints in a deck shall be provided to minimize visible cracks outside of the control joints caused by imposed stresses or movement of the slab.

TABLE 306.5
MINIMUM DRAINAGE SLOPES FOR DECK SURFACES

SURFACE	MINIMUM DRAINAGE SLOPE (INCH PER FOOT)
Carpet	1/2
Exposed aggregate	1/2
Textured, hand-finished concrete	1/8
Travertine/brick-set pavers, public pools or spas	1/8
Travertine/brick-set pavers, residential pools or spas	1/8
Wood	1/8
Wood/plastic composite	1/4

For SI: 1 inch = 25.4 mm, 1 foot = 304.8 mm.

306.7.3 Movement control. Areas where decks join existing concrete work shall be provided with a joint to protect the pool from damage caused by relative movement.

306.8 Deck edges. The edges of decks shall be railed, tapered, or otherwise designed to eliminate sharp corners.

306.9 Valves under decks. Valves installed in or under decks shall be accessible for operation, service, and maintenance. Where access through the deck walking surface is required, an access cover shall be provided for the opening in the deck. Such access covers shall be slip resistant and secured.

306.9.1 Hose bibbs. Hose bibbs shall be provided for rinsing down the entire deck and shall be installed in accordance with the *International Plumbing Code* or *International Residential Code*, as applicable in accordance with Section 102.7.1, and shall be located not greater than 150 feet (45 720 mm) apart. Water-powered devices, such as water-powered lifts, shall have a dedicated hose bibb water source.

Exception: *Residential* pools and spas shall not be required to have hose bibbs located at 150-foot (45 720 mm) intervals, or have a dedicated hose bibb for water-powered devices.

**SECTION 307
GENERAL DESIGN**

J 307.1 General design requirements. Sections 307.1.1 through 307.1.4 shall apply to all pools and spas.

307.1.1 Glazing in hazardous locations. Hazardous locations for glazing shall be as defined in the *International Building Code* or the *International Residential Code*, as applicable in accordance with Section 102.7.1 of this code. Where glazing is determined to be in a hazardous location, the requirements for the glazing shall be in accordance with those codes, as applicable.

307.1.2 Colors and finishes. For other than *residential* pools and *residential* spas, the colors, patterns, or finishes of the pool and spa interiors shall not obscure objects or surfaces within the pool or spa.

307.1.3 Roofs or canopies. Roofs or canopies over pools and spas shall be in accordance with the *International Building Code* or *International Residential Code*, as applicable in accordance with Section 102.7.1 and shall be constructed so as to prevent water runoff into the pool or spa.

307.1.4 Accessibility. An accessible route to public pools and spas shall be provided in accordance with the *International Building Code*. Accessibility within public pools and spas shall be provided as required by the accessible recreational facilities provisions of the *International Building Code*.

307.2 Specific design and material requirements. Sections 307.2.1 through 307.2.4 shall apply to all pools and spas except for *listed* and *labeled* portable *residential* spas, and *listed* and *labeled* portable *residential* exercise spas.

307.2.1 Materials. Pools and spas and appurtenances thereto shall be constructed of materials that are nontoxic to humans and the environment; that are generally or com-

monly regarded to be impervious and enduring; that will withstand the design stresses; and that will provide a watertight structure with a smooth and easily cleanable surface without cracks or joints, excluding structural joints, or that will provide a watertight structure to which a smooth, easily cleaned surface/finish is applied or attached. Material surfaces that come in contact with the user shall be finished, so that they do not constitute a cutting, pinching, puncturing or abrasion hazard under casual contact and intended use.

307.2.1.1 Beach pools. Clean sand or similar material, where used in a beach pool environment, shall be used over an impervious surface. The sand area shall be designed and controlled so that the circulation system, maintenance, safety, sanitation, and operation of the pool are not adversely affected.

307.2.1.2 Compatibility. Assemblies of different materials shall be chemically and mechanically compatible for their intended use and environment.

307.2.2 Materials and structural design. Pools and spas shall conform to one or more of the standards indicated in Table 307.2.2. The structural design of pools and spas shall be in accordance with the *International Building Code* or the *International Residential Code*, as applicable in accordance with Section 102.7.1 of this code.

**TABLE 307.2.2
RESERVOIRS AND SHELLS**

MATERIAL	STANDARD
Fiberglass reinforced plastic	IAPMO Z124.7
Plastic	IAPMO Z124.7
Stainless steel (Types 316, 316L, 304, 304L)	ASTM A240
Tile	ANSI A108/A118/A136.1
Vinyl	ASTM D1593

307.2.2.1 Installation. Equipment for pools and spas shall be supported to prevent damage from misalignment and settling and located so as to allow access for inspection, servicing, removal and repair of component parts.

307.2.2.3 Freeze protection. In climates subject to freezing temperatures, outdoor pool and spa shells and appurtenances, piping, filter systems, pumps and motors, and other components shall be designed and constructed to provide protection from damage from freezing.

307.2.4 Surface condition. The surfaces within public pools and spas intended to provide footing for users shall be slip resistant and shall not cause injury during normal use.

**SECTION 308
DIMENSIONAL DESIGN**

308.1 Floor slope. The slope of the floor from the point of the first slope change to the deep area shall not exceed one unit vertical in three units horizontal (33-percent slope).

Exception: Portable *residential* spas and portable *residential* exercise spas.